

SYSTEM: OMNICOMPACT



Product description

In the event of an alarm, self-closing, thermally insulating Fire protection closure in the design of a lifting staggered door in vertical installation position and closing direction

Type	Heat-insulating fire protection closure in the design of a lifting staggered door
Verification	CE identification pursuant to EN 16034:2014 in conjunction with EN 13241:2003+A2:2016
Closing direction	From top to bottom
Fire resistance	EI 30 – EI 120 tested in compliance with EN 1634-1:2014-03 classified according to EN 13501-2:2016
Closing cycles	C0, C1, C2 tested in compliance with EN 12605:2000-08 classified according to EN 13501-2:2016
Environment conditions	Special environmental conditions are not taken into account (e.g. humidity > 80 %, ambient temperature < 5 °C and > 45 °C, wind loads etc.).
Visible surfaces of the housing and guide rails	galvanized, RAL - smooth - silk gloss - standard shade NCS - standard shade

Size dimensions and system structure

Due to the combination of classifications or the ratio of clear system width to clear system height, the stated maximum dimensions may be reduced and the dimensions of the enclosure and guide rails may vary. The specifications on the quotation apply.

Classification	Size max.* [y x r] in mm	Fabric/component	Wall thickness** in mm	Housing	Guide rail
EI ₁ 30	6450 x 6225	Slat	240	A, B, C	Type 1
EI ₂ 30	6450 x 6225	Slat	240	A, B, C	Type 1
EI ₁ 60	6450 x 6225	Slat	240	A, B, C	Type 1
EI ₂ 60	6450 x 6225	Slat	240	A, B, C	Type 1
EI ₁ 90	6450 x 6225	Slat	240	A, B, C	Type 1
EI ₂ 90	6450 x 6225	Slat	240	A, B, C	Type 1
EI ₁ 120	4300 x 4150	Slat	240	A, B, C	Type 1
EI ₂ 120	4300 x 4150	Slat	240	A, B, C	Type 1
C0, C1, C2	6000 x 5598	Slat			

The installation situation must comply with the building code requirements of the country of installation. The fire resistance of a ceiling or wall support structure and the adjacent components must at least correspond to that of the fire and/or smoke protection closure/fire and/or smoke protection curtain. Evidence of the stability and serviceability of the adjacent walls and components must be provided under general ambient conditions and in the event of fire. See also notes on the standard supporting structure in EN 1366-7:2004 or EN 1363-1:2020. The fire protection system must not be subjected to any additional loads other than its own weight, even in the event of fire.

* Deviations from size dimensions on request

** tested wall types according to the installation instructions

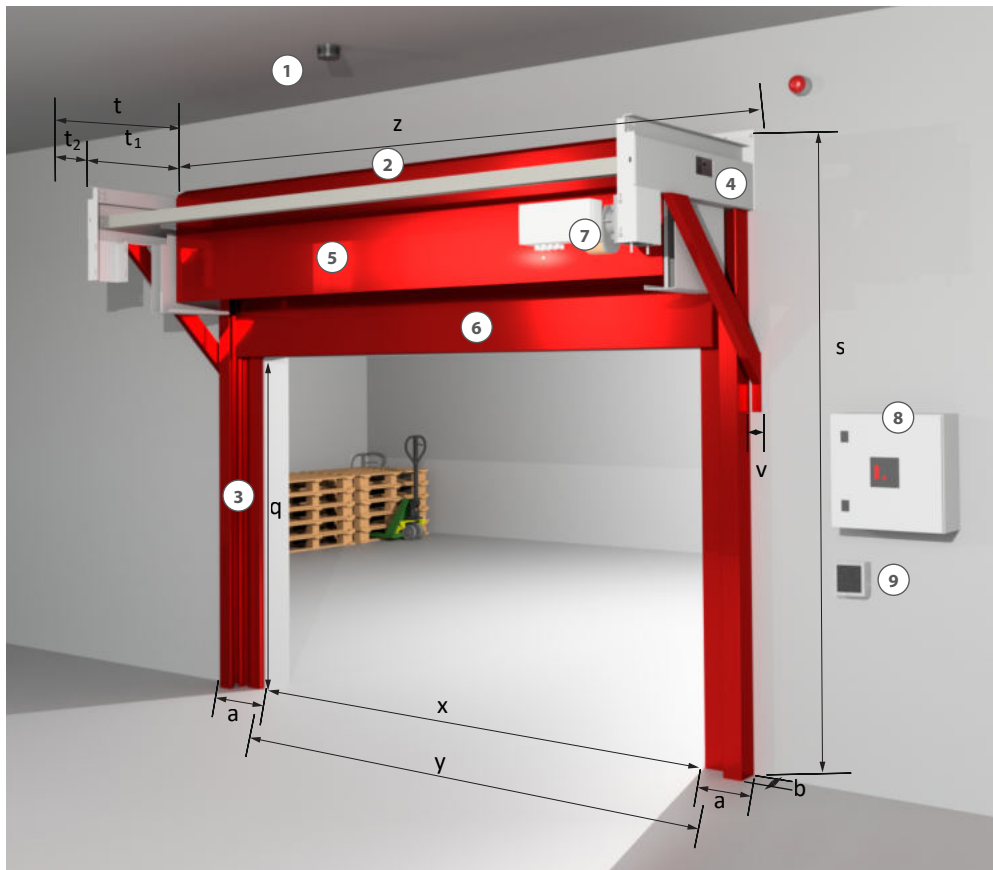

Legend system components:

- 1 = Smoke detector
- 2 = Housing
- 3 = Guide rails
- 4 = Mounting bracket
- 5 = Slat
- 6 = End element
- 7 = Drive motor
- 8 = Control with operating unit
- 9 = Handauslöser optional
(Manual release necessary if the control unit with operating unit is mounted higher than 1.4 m above the upper edge of the finished floor)

Legende Vermaßung:

Building

- q = clear headroom
- x = clear structural width

System

- s = System height
- y = clear system width
- z = System width

Housing

- t = Depth
- t₁ = Console
- t₂ = Space requirement control box lid
- h = Height
- v = Offset between winding housing and guide rail

Guide rail

- a = Width
- b = Depth

Housing

Overlap lintel and vertical Sealing frame with bracket

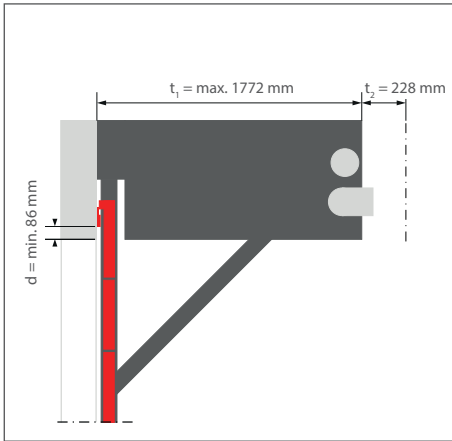

Type A

Suspension of drive shaft with clear Shell construction width > 4500 mm via gallows

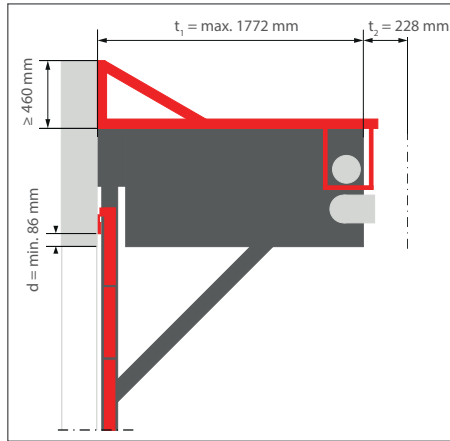

Type B

Suspension of drive shaft with clear Shell construction width > 4500 mm above ceiling

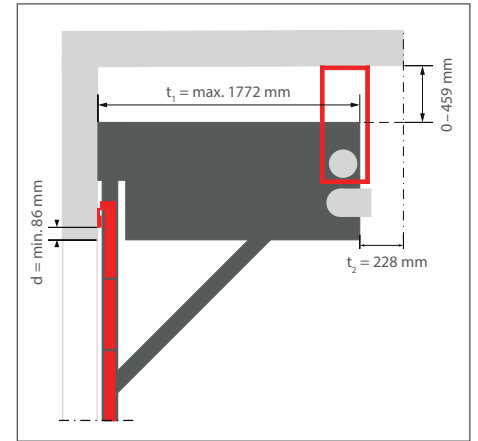

Type C

Guide rails

Type 1

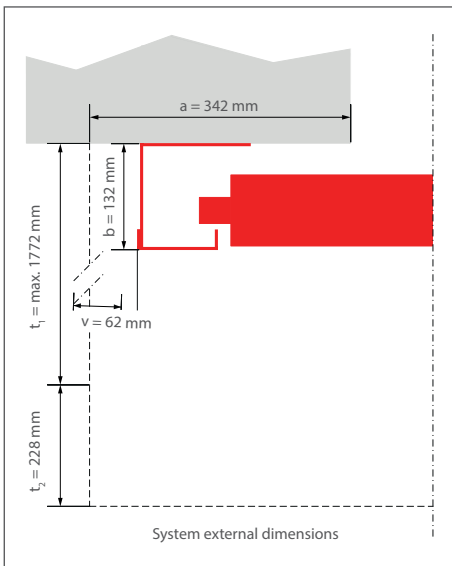

Bracket length as a function of number of slats/clearance height in mm	
t_1	872
	1072
	1272
	1372
	1472
	1572
	1672
	1772